

Hybrid HC20

Designed for efficiency, built to last



HYBRID HC20

Quieter, easier to push, with the durability of steel

- > *FDA-approved resin, rivet-free one-piece basket reduces overall cart weight*
- > *Contoured Basket design minimizes moisture and dirt for cleanliness and hygiene*
- > *Quiet and comfortable with fixed lower grill and easy-grip front handles*



3 LOGO PANELS

Also available for an optional printing logo on the sides and front 8" x 3 1/2".

Print available in one color only.



OPTIONAL ATTACHMENTS

Optional bread basket insert and cup holder attachments are available.



CUSTOMIZABLE HANDLE

Retailers can customize the handle with a logo to increase brand awareness.



HYBRID HC20

1 The Interchangeable One-Piece Basket is exclusively attached without the use of rivets, a common area of failure on other plastic cart designs.

2 High Visibility Basket provides cashier with clear vision to all items in the basket thus reducing theft.

3 Contemporary Contoured Basket design reduces the collection of moisture and dirt, reducing slip-and-fall potential and provides the customer with a clean shopping cart.

4 Integrated front handle.

5 Modular Design allows for easy maintenance.

6 Fixed Lower Grill reduces noise.

7 Steel Components include TECH-SEAL® finish (three-year written warranty against the spread of corrosion). Steel frame and Components standard in Granite TECH-SEAL® Finish

8 Heavy-Gauge Oval Tube Frame

9 Unique Steel Gate Design eliminates gate from dislodging from basket.

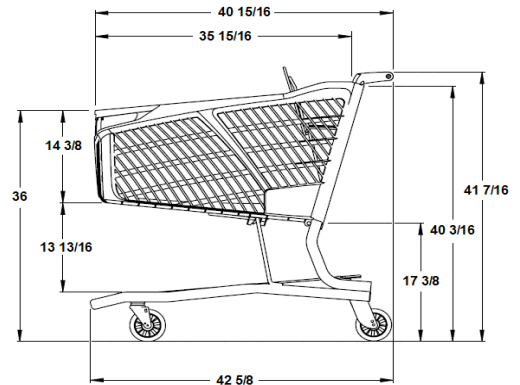
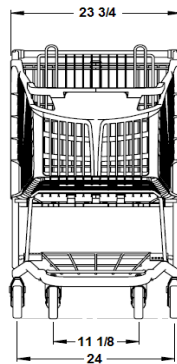

AVAILABLE BASKET COLORS



Black Grey Red Green Blue

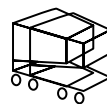

TOTAL PAYLOAD	TOP BASKET CAPACITY	NESTING DISTANCE	WEIGHT	53' TRAILER MAXIMUM CAPACITY
18,120 in ³	11,120 in ³	10.5 in	53.5 lbs	550 Carts
297 Liters	182 Liters	26.7 cm	24.3 kg	3 Layer Stacking



Wanzl worldwide

- Head Office
- North America HQ
- Subsidiaries
- Partners

WANZL NORTH AMERICA
700 Technibilt Drive
PO Box 310
Newton, NC 28658

Phone +1 828-464-7388
Fax +1 800-968-8934

info-wna@wanzl.com
www.wanzl.com/na

GERMANY
Wanzl GmbH & Co. KGaA
Rudolf-Wanzl-Straße 4
89340 Leipheim

Phone +49 (0) 82 21 / 7 29-0
Fax +49 (0) 82 21 / 7 29-1000

info@wanzl.com
www.wanzl.com